



Model 475STDA

Reduced Pressure Detector Assembly

Application

Designed for drop in replacement of competitor valves and new installation on water lines in fire protection systems to protect against both backsiphonage and backpressure of contaminated water into the potable water supply. The Model 475STDA shall provide protection where a potential health hazard exists. The configuration 475STDAV is for applications requiring vertical flow up. Incorporates metered by-pass to detect leaks and unauthorized water use.

Standards Compliance

- Approved by the Foundation for Cross Connection Control and Hydraulic Research at the University of Southern California
- ASSE® Listed 1047
- AWWA Compliant C550
- CSA® Certified B64.4
- UL® Classified
- C-UL® Classified
- FM® Approved
- Meets the requirements of NSF/ANSI 61*

*(0.25% MAX. WEIGHTED AVERAGE LEAD CONTENT)

By-Pass Backflow Assembly 3/4" Model 975XLDTCU

Materials

Main valve body	304L Stainless steel
Access covers	304L Stainless steel
Internals Stainless steel,	300 Series
	NORYL™, NSF Listed
Fasteners & Springs	Stainless Steel, 300 Series
Elastomers	EPDM (FDA approved)
	Buna Nitrile (FDA approved)
Polymers	NORYL™, NSF Listed
Sensing line	Stainless steel, braided hose

Features

Sizes: 4", 6", 8", 10"	
Maximum working water pressure	175 psi
Minimum working water pressure	25 psi
Maximum working water temperature	140° F
Minimum working water temperature	33° F
Hydrostatic test pressure	350 psi
End connections	
(Grooved for steel pipe)	AWWA C606
(Flanged bolt pattern)	ASME B16.42
	Class 150



LEAD FREE



NSF/ANSI 61

Options

(Suffixes can be combined)

- with OS & Y gate valves (standard)
- LM - less water meter
- with remote reading meter
- with gpm meter (standard)
- with cu ft/min meter
- V - vertical flow up configuration
- G - with groove end gate valves
- FG - with flanged inlet gate connection and grooved outlet gate connection
- MS - with integral relief valve monitor switch
- BG - with grooved end butterfly valves with integral supervisory switches
- BF - with flanged end butterfly valves with integral supervisory switches
- PI - with post indicator gate valve
- RV - with relief valve, by-pass and shut-off valves on reverse side

Accessories

- Air gap (see spec sheet BF-AG)
- Repair kit (rubber only)
- Thermal expansion tank (Model XT)
- Valve setter (Model FLSST or MJSST or MJFSST)
- Gate valve tamper switch (OSY-40)
- QT-SET Quick Test Fitting Set

Relief Valve discharge port;
2 1/2" - 6" - 2.75 sq. in.
8" - 10" - 3.69 sq. in.

Dimensions & Weights (do not include pkg.)

SIZE	WEIGHT							
	WITH OS&Y GATES (GXF)		WITH OS&Y GATES (GXG)		WITH BFLY VALVES (GXF)		WITH BFLY VALVES (GXG)	
	lbs.	kg	lbs.	kg	lbs.	kg	lbs.	kg
4"	215	98	195	89	166	75	143	65
6"	343	155	319	144	232	105	201	91
8"	594	269	556	252	440	200	394	179
10"	837	379	783	355	549	249	491	223

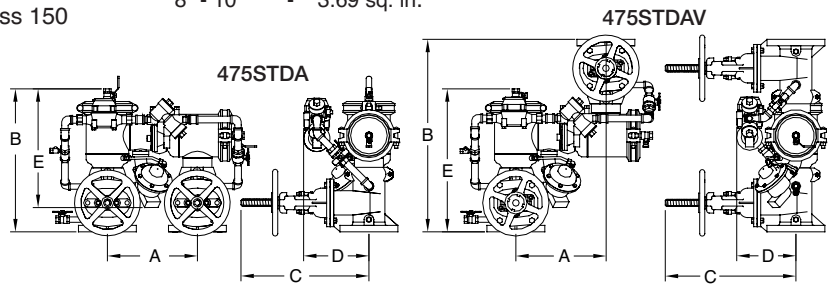

SIZE	DIMENSION (approximate)																		
	A		B WITH GATE VALVES		B WITH BUTTERFLY VALVES		C OS&Y OPEN		C OS&Y CLOSED		C WITH BUTTERFLY VALVES		D		E		E WITH BUTTERFLY VALVES		
	in.	mm	in.	mm	in.	mm	in.	mm	in.	mm	in.	mm	in.	mm	in.	mm	in.	mm	
4" 475STDA	100	14	356	22 1/4	565	19 7/8	505	22 1/2	572	9	229	9	229	10 1/8	257	18 3/8	467	18 3/8	467
4" 475STDAV	100	14	356	29 7/8	760	25 1/8	638	22 1/2	572	9	229	9	229	10 1/8	257	22 1/4	565	19 7/8	505
6" 475STDA	150	16	406	27 7/8	708	24 3/4	630	30 1/2	775	10 1/2	267	10 1/4	260	10 5/8	270	22 3/8	570	22 3/8	570
6" 475STDAV	150	16	406	36 1/4	921	29 1/8	740	30 1/2	775	10 1/2	267	10 1/4	260	10 5/8	270	27 7/8	708	24 3/4	630
8" 475STDA	200	18 1/2	470	34 7/8	886	29 1/8	740	37	940	12	305	12	305	12 7/8	327	30 5/8	780	30 5/8	780
8" 475STDAV	200	18 1/2	470	40 1/4	1022	33 1/8	841	37	940	12	305	12	305	12 7/8	327	34 7/8	886	29 1/8	740
10" 475STDA	250	21	533	38 3/4	984	35 3/4	910	45 5/8	1159	12	305	13	330	12 7/8	327	32 3/4	832	32 3/4	832
10" 475STDAV	250	21	533	45 7/8	1165	39 13/16	1011	45 5/8	1159	12	305	13	330	12 7/8	327	38 3/4	984	35 3/4	908

475STDA & 475STDAV 4" & 6" (STANDARD & METRIC)

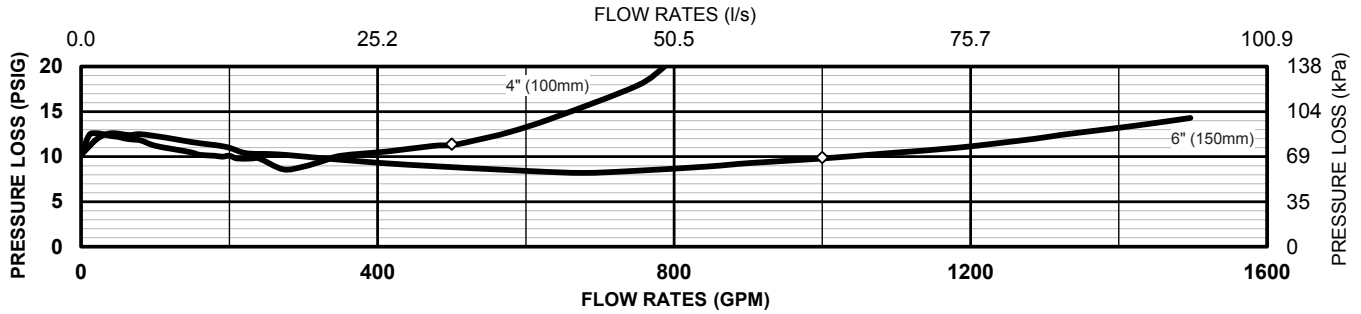

475STDA & 475STDAV 8" & 10" (STANDARD & METRIC)

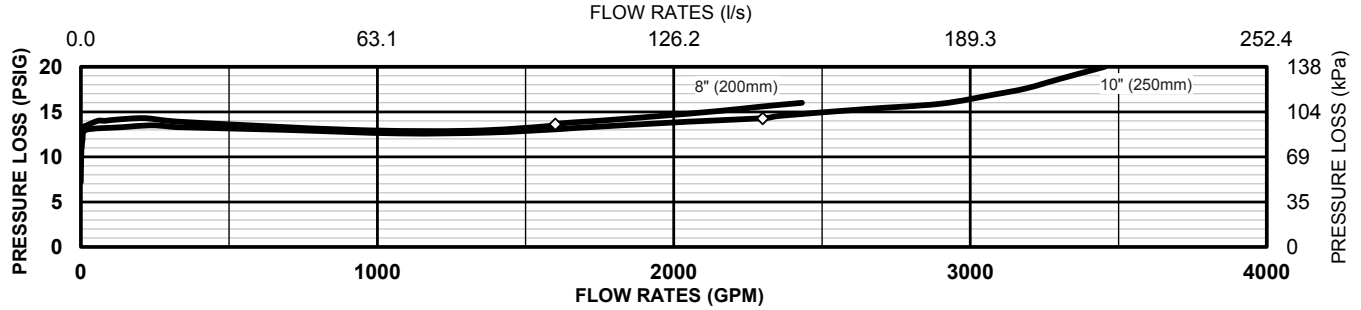

Typical Installation

Local codes shall govern installation requirements. To be installed in accordance with the manufacturers' instructions and the latest edition of the Uniform Plumbing Code. Unless otherwise specified, the assembly shall be mounted above adequate drains with sufficient side clearance for testing and maintenance. The installation shall be made so that no part of the unit can be submerged.

Capacity thru Schedule 40 Pipe (GPM)				
Pipe size	5 ft/sec	7.5 ft/sec	10 ft/sec	15 ft/sec
2 1/2"	75	112	149	224
3"	115	173	230	346
4"	198	298	397	595
6"	450	675	900	1351
8"	780	1169	1559	2339
10"	1229	1843	2458	3687

MODEL SIZE	DIMENSIONS (approximate)				
	A1 SETTER END TO END FLS		A1 SETTER END TO END MJS		
in.	mm	in.	mm	in.	mm
4	100	27	686	30	762
6	150	32	813	35	890
8	200	36 1/2	927	39	991
10	250	43	1092	45	1143

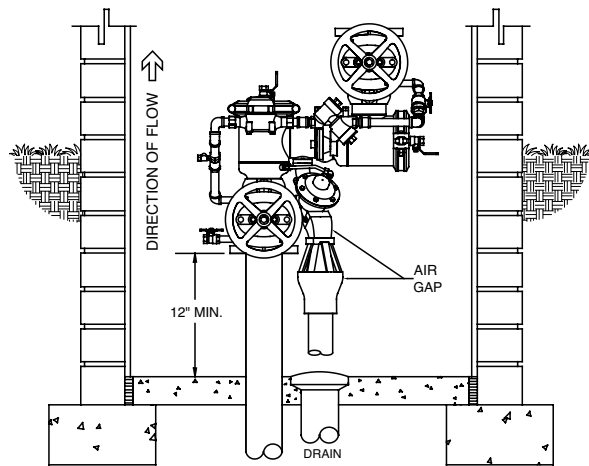

VERTICAL INSTALLATION

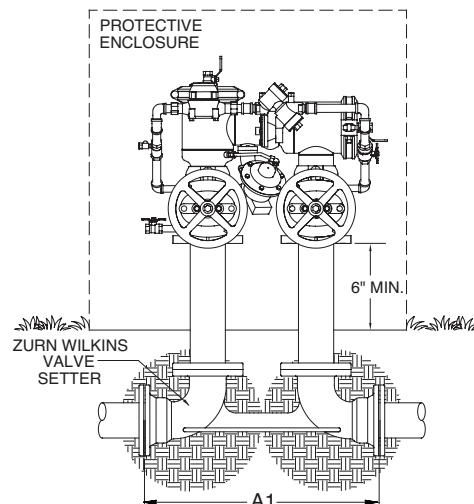

OUTDOOR INSTALLATION

Specifications

The Reduced Pressure Detector Backflow Prevention Assembly shall be certified to NSF/ANSI 61, ASSE® Listed 1047, and supplied with full port OS & Y gate valves. The main body and access cover shall be 304L Stainless Steel, the seat ring and check valve shall be NORYL™, the stem shall be stainless steel (ASTM A 276) and the seat disc elastomers shall be EPDM. The checks and the relief valve shall be accessible for maintenance without removing the device from the line. The Reduced Pressure Detector Backflow Prevention Assembly shall be a ZURN WILKINS Model 475STDA.