

INSTALLATION INSTRUCTIONS

Series 805Y, 805YD, 806YD

Double Check Detector Assemblies

Sizes: 3/4" – 10" (20 – 250mm)

Installation Instructions

1. Consult local codes for specific installation requirements and restrictions applicable to your area. It is recommended that system supply pressure be at least 20psi (138 kPa).
2. These instructions apply only to Series 805Y sizes 3/4" – 2" (20 – 50mm), 805YD sizes 2 1/2" – 10" (65 – 250mm), and 806YD sizes 3" – 10" (80 – 250mm). The valves may be installed only in the orientation/flow directions as shown. The gate valves may be rotated, as permitted by the flange bolt pattern, on vertical installations only.
3. The valve assembly must be installed where it is accessible for periodic testing and maintenance. Clearances shown in the installation views apply to exterior, interior and pit/vault installations and are only recommendations. These minimums do not apply to removable protective enclosures. Refer to local codes for actual requirements in your area.
4. **PRIOR TO INSTALLING THE VALVE INTO THE LINE, FLUSH THE SUPPLY LINE OF ALL FOREIGN MATERIAL.** Failure to flush the supply line may cause the check valves to become fouled and require disassembly and cleaning.
5. Lift the assembly by the valve body. **DO NOT LIFT THE ASSEMBLY BY CONNECTING TO THE VALVE HANDLES, STEMS, OR BYPASS PIPING.** On 2 1/2" – 10" (65 – 250mm) units lift eyes are bolted to the check covers.
6. After installation **SLOWLY** fill the assembly with water and bleed air from the body using the # 2, # 3 and # 4 test cocks. Test the valve assembly to ensure correct operation.

NOTE: All assemblies are tested at the factory for proper operation and leakage. If the valve does not pass the field test, it is most likely due to a fouled check valve. This is not covered by the factory warranty. The valve cover(s) must be removed and the check seats inspected and cleaned. Any damage or improper operation caused by pipeline debris or improper installation/start-up is not included in the factory warranty.

In case of a possible warranty claim, contact your local supplier or FEBCO Representative. **DO NOT REMOVE THE VALVE ASSEMBLY FROM THE PIPELINE.**

7. The assembly must be protected from freezing and excessive pressure increases. Pressure increases can be caused by thermal expansion or water hammer. These excessive pressure situations must be eliminated to protect the valve and system from possible damage.
8. Plastic testcock plugs and tethers are provided for the Series 805Y (loose in box) for areas that require them.

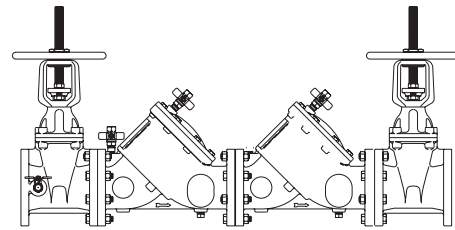

Figure 1

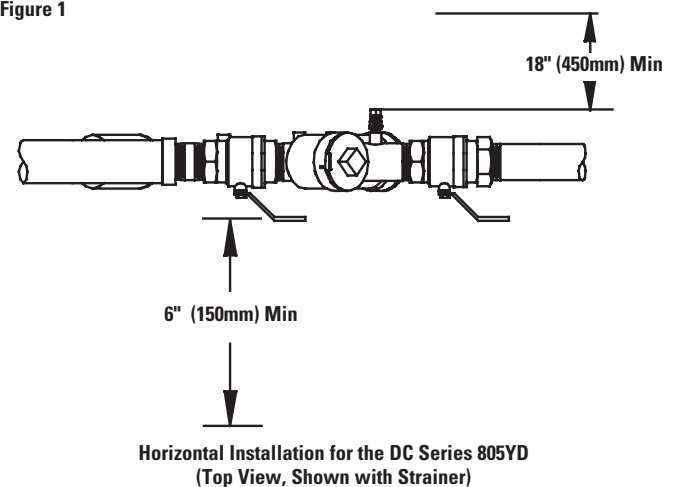
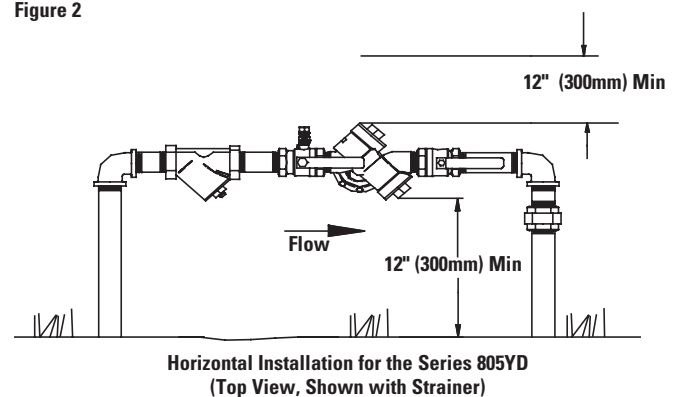

Figure 2



Service and Maintenance

General

1. Detailed maintenance manuals are available from your local FEBCO representative.
2. Rinse all parts with clean water prior to reassembly.
3. **DO NOT USE ANY PIPE DOPE, OIL, GREASE, OR SOLVENT ON ANY PARTS** unless instructed to do so.
4. Do not force parts. Parts should fit together freely. Excess force may cause damage and render the assembly inoperable.
5. Carefully inspect seals and seating surfaces for debris or damage.
6. After servicing, repressurize the assembly and test to ensure proper operation.

Check Valve Disassembly

1. Close the outlet shutoff valve, then close the inlet shutoff valve. Bleed residual pressure from the assembly by opening the #4, #3 and #2 tests cocks in this sequence.
2. Unscrew/Unbolt the cover and remove the spring and disc holder assembly. **NOTE:** Unbolt covers on valves 4" (100mm) and larger have their springs retained and the covers should push away from the body approximately 1/4" (8mm) as the bolts are loosened. **CAUTION:** The covers on valves 3" (80mm) and smaller are spring loaded.
3. Inspect/clean debris from the disc and seat area. Replace worn/damaged parts as required.
4. Reassemble the valve in the reverse order of disassembly.

Test Procedure

FEBCO recommends the use of the appropriate test method presented in the ASSE Series 5000 manual that is consistent with your local codes.

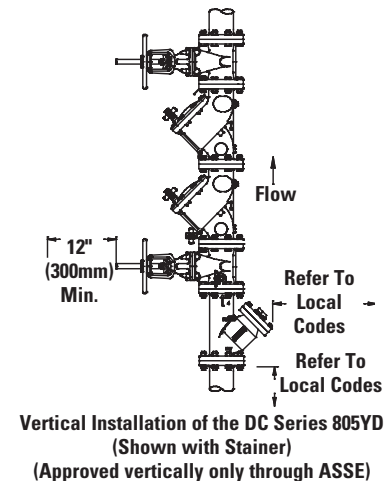
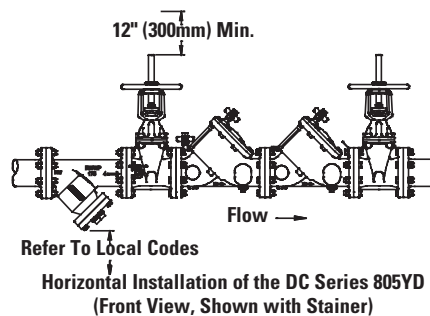
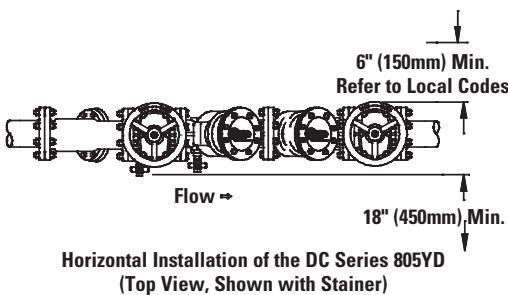

Troubleshooting

PROBLEM	CAUSE	SOLUTION
1. Check valve leaking	a. Debris on check seating surfaces b. Leaking shutoff valve	Disassemble/clean Disassemble/clean
2. Low flows passing through mainline valve (DCDA)	a. Mainline check fouled b. Bypass line plugged	Disassemble/clean Disassemble/clean

CALIFORNIA PROPOSITION 65 WARNING

WARNING: This product contains chemicals known to the State of California to cause cancer and birth defects or other reproductive harm. (California law requires this warning to be given to customers in the State of California.)

For more information: www.watts.com/prop65

Limited Warranty: FEBCO warrants each product to be free from defects in material and workmanship under normal usage for a period of one year from the date of original shipment. In the event of such defects within the warranty period, the Company will, at its option, replace or recondition the product without charge.

THE WARRANTY SET FORTH HEREIN IS GIVEN EXPRESSLY AND IS THE ONLY WARRANTY GIVEN BY THE COMPANY WITH RESPECT TO THE PRODUCT. THE COMPANY MAKES NO OTHER WARRANTIES, EXPRESS OR IMPLIED. THE COMPANY HEREBY SPECIFICALLY DISCLAIMS ALL OTHER WARRANTIES, EXPRESS OR IMPLIED, INCLUDING BUT NOT LIMITED TO THE IMPLIED WARRANTIES OF MERCHANTABILITY AND FITNESS FOR A PARTICULAR PURPOSE.

The remedy described in the first paragraph of this warranty shall constitute the sole and exclusive remedy for breach of warranty, and the Company shall not be responsible for any incidental, special or consequential damages, including without limitation, lost profits or the cost of repairing or replacing other property which is damaged if this product does not work properly, other costs resulting from labor charges, delays, vandalism, negligence, fouling caused by foreign material, damage from adverse water conditions, chemical, or any other circumstances over which the Company has no control. This warranty shall be invalidated by any abuse, misuse, misapplication, improper installation or improper maintenance or alteration of the product.

Some States do not allow limitations on how long an implied warranty lasts, and some States do not allow the exclusion or limitation of incidental or consequential damages. Therefore the above limitations may not apply to you. This Limited Warranty gives you specific legal rights, and you may have other rights that vary from State to State. You should consult applicable state laws to determine your rights. **SO FAR AS IS CONSISTENT WITH APPLICABLE STATE LAW, ANY IMPLIED WARRANTIES THAT MAY NOT BE DISCLAIMED, INCLUDING THE IMPLIED WARRANTIES OF MERCHANTABILITY AND FITNESS FOR A PARTICULAR PURPOSE, ARE LIMITED IN DURATION TO ONE YEAR FROM THE DATE OF ORIGINAL SHIPMENT.**

