

Application

Designed for installation on potable water lines to protect against both backsiphonage and backpressure of polluted water into the potable water supply. The Model 450 shall provide protection where a potential health hazard does not exist. Ideal for use where lead-free* valves are required.

Standards Compliance

- ASSE® Listed 1015
- AWWA Compliant C510, and C550
- UL® Classified
- C-UL® Classified
- FM® Approved
- NYC MEA 213-99-M VOL 3
- Approved by the Foundation for Cross Connection Control and Hydraulic Research at the University of Southern California
- Meets the requirements of NSF/ANSI 61*

*(0.25% MAX. WEIGHTED AVERAGE LEAD CONTENT)

Materials

Main valve body	Ductile Iron ASTM A 536 Grade 4
Access covers	Ductile Iron ASTM A 536 Grade 4
Coatings	FDA Approved fusion epoxy finish
Internals	Stainless steel, 300 Series NORYL™
Fasteners	Stainless Steel, 300 Series
Seal ring	EPDM (FDA approved)
O-ring	Buna Nitrile (FDA approved)
Springs	Stainless Steel, 300 Series

Features

Sizes:	2 1/2" & 3"
Maximum working water pressure	175 PSI
Maximum working water temperature	140°F
Hydrostatic test pressure	350 PSI
End connections	
(Grooved for steel pipe)	AWWA C606
(Flanged)	ANSI B16.1 Class 125



LEAD FREE



NSF/ANSI 61

Options

(Suffixes can be combined)

- with NRS shut-off valves (standard)
- FSC - with epoxy coated wye type strainer (flanged only)
- G - with groove end gate valves
- GF - with grooved inlet gate connection and flanged outlet gate connection
- FG - with flanged inlet gate connection and grooved outlet gate connection
- L - less shut-off valves (flanged body connections)
- OSY - with OS & Y gate valves
- 509 - with AWWA C509 gate valves

Accessories

- Repair kit (rubber only)
- Thermal expansion tank (Model XT)
- OS & Y Gate valve tamper switch (OSY-40)
- QT-SET Quick Test Fitting Set

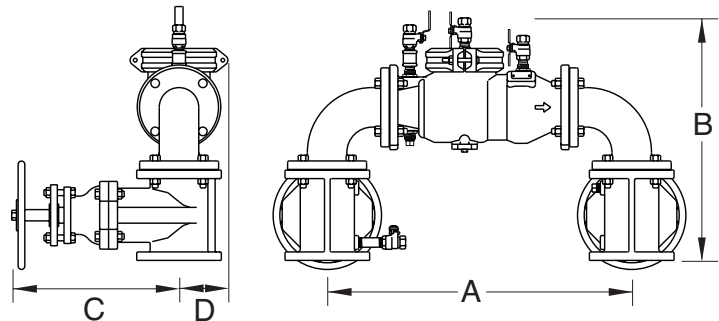

Dimensions & Weights (do not include pkg.)

MODEL 450 SIZE	DIMENSION (approximate)												WEIGHT						
	A		B		C OS&Y OPEN		C OS&Y CLOSED		C NRS GATES		D		WITHOUT GATE VALVES		WITH NRS GATE VALVES		WITH OS&Y GATE VALVES		
	in.	mm	in.	mm	in.	mm	in.	mm	in.	mm	in.	mm	lbs.	kg	lbs.	kg	lbs.	kg	
2 1/2	65	26	660	20 1/2	521	16 3/8	416	13 7/8	352	11 3/8	289	3 3/4	95	80	36.3	182	82.6	190	86.3
3	80	27	686	21 1/2	546	18 7/8	479	15 5/8	397	12 3/8	314	3 3/4	95	83	37.7	207	94	213	96.7

MODEL 450 2 1/2" & 3" (STANDARD & METRIC)

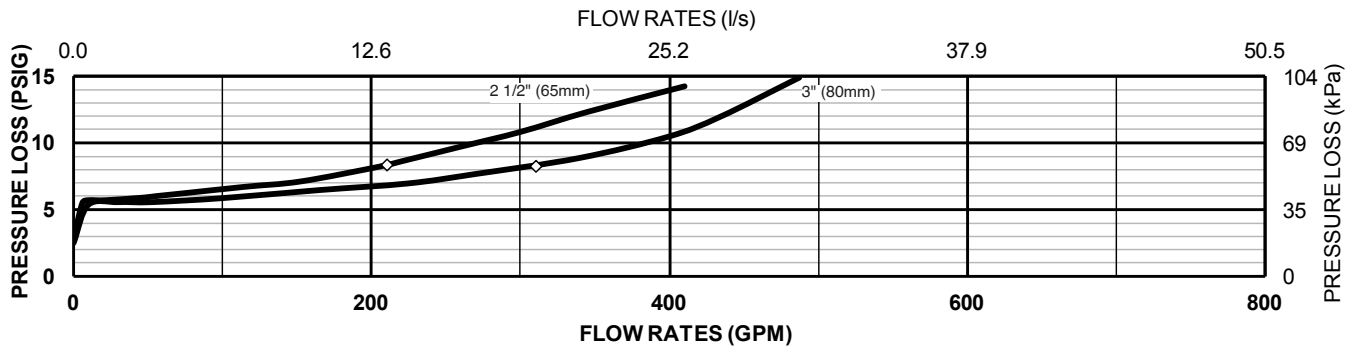

Typical installation

Local codes shall govern installation requirements. Unless otherwise specified, the assembly shall be mounted above adequate drains with sufficient side clearance for testing and maintenance. The installation shall be made so that no part of the unit can be submerged.

Capacity thru Schedule 40 Pipe (GPM)				
Pipe size	5 ft/sec	7.5 ft/sec	10 ft/sec	15 ft/sec
2 1/2"	75	112	149	224
3"	115	173	230	346
4"	198	298	397	595
6"	450	675	900	1351
8"	780	1169	1559	2339
10"	1229	1843	2458	3687

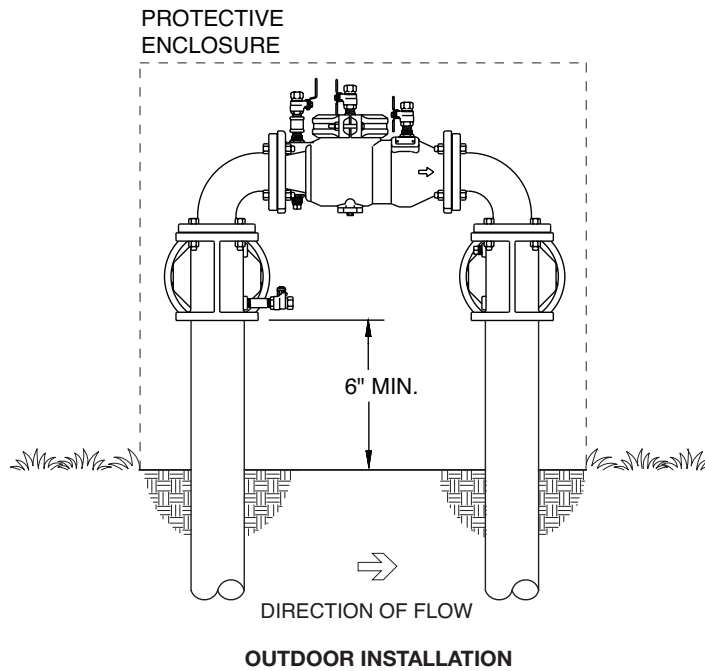

Specifications

The Double Check Backflow Prevention Assembly shall be certified to NSF/ANSI 61, ASSE® Listed 1015, and supplied with full port gate valves. The main body and access cover shall be epoxy coated ductile iron (ASTM A 536 Grade 4), the seat ring and check valve shall be NORYL™, the stem shall be stainless steel (ASTM A 276) and the seat disc elastomers shall be EPDM. The checks shall be accessible for maintenance without removing the device from the line. The Double Check Backflow Prevention Assembly shall be a ZURN WILKINS Model 450.