

FEBCO Operation and Maintenance

805Y / 805YB / 805YS

Double Check Assembly (3/4" – 2")

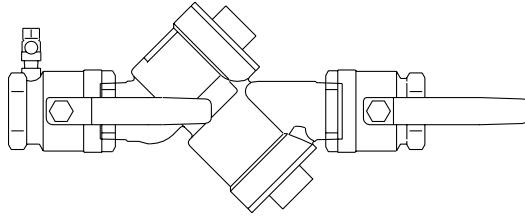

FEATURES AND OPERATING PROCEDURES

This device consists of two independently operating poppet type check valves. Each check valve is spring loaded to maintain a minimum of 1 PSIG differential pressure across the check in a no-flow condition. In a normal flow condition the checks open an amount corresponding to the flow rate. During a backflow (backpressure) situation the seat discs close and seal to prevent any flow reversal. Sizes 3/4" through 2" (805Y, 805YB, 805YS, 805YR) include two spring-loaded, Y-pattern bronze check valves, two bronze shut-off valves and four testcocks for field testing. All valves are threaded type and the unit is shipped completely assembled.

GENERAL SERVICE PROCEDURES (General service instructions applicable to all sizes.)

1. Rinse all parts with clean water prior to assembly.
2. DO NOT USE ANY PIPE DOPE, OIL, GREASE OR SOLVENT ON ANY PARTS unless instructed to do so.
4. Do not force parts. Parts should fit freely together. Excess force may cause damage and render the device inoperable.
5. Carefully inspect seals, seating surfaces, etc. for damage or debris.
5. Test unit after servicing to insure proper operations.
6. Refer to applicable parts list and figures for more information.
7. A table on page 3 provides size and material information for standard parts (non-special design). These parts can usually be purchased locally from parts distributors.
8. Some water conditions can cause a buildup of calcium or similar material deposits on some moving parts. Normally this condition would not occur on devices used in systems with varying flow rates. The scraping action of moving parts helps to remove any deposits. However, with devices used on static systems such as firelines, any deposits would not be scraped away and could interfere with the check valve operation. Devices in these applications should be disassembled and inspected on a periodic basis depending on water quality. Any deposits should be removed from the center guiding stem and bushings. Use care to avoid damage to guiding surfaces.

TROUBLESHOOTING GUIDE

Symptom #1	Cause:	Solution:
Check fails to hold 1.0 PSID min.	A. Debris on sealing surfaces	Disassemble and clean
	B. Leaking shut-off valve	Disassemble and clean or repair
	C. Damaged seat disc or seat ring	Disassemble and replace
	D. Damaged guide holding check open	Disassemble and replace guide pin and/or sleeve bushing
	E. Weak or broken spring	Disassemble and replace spring

Symptom #2	Cause:	Solution:
Chatter during flow conditions.	A. Worn or damaged guide	Disassemble and repair or replace guide

Symptom #3	Cause:	Solution:
Low flows passing through the mainline valve.	A. Mainline check fouled	Inspect and clean, or repair

SERVICE PROCEDURES FOR MODELS 805Y, 805YB, 805YS

1. Disassembly-Check Valves

- a. Close inlet and outlet shut-off valves. Bleed residual pressure by opening #2, #3 and #4 testcocks.
- b. Unscrew cap using appropriate size wrench. **NOTE: Cap is spring loaded.**
- c. Remove the spring and check assembly.
- d. If any calcium or similar material has built-up on the inside surfaces of the guidehole in the cap, it can be removed with careful use of a standard reamer.
 - (1) 3/4" through 1" devices: .6250 (5/8) Reamer
 - (2) 1 1/2" and 2" devices: .8750 (7/8) Reamer

2. Check Valve Seal Replacement

- a. Hold check assembly in one hand and remove screw, washer, and seat disc. **CAUTION:** The use of pliers or other tools may damage the parts and require unnecessary replacement. Do not scratch or mark sealing or guiding surfaces.
- b. Install new disc after cleaning disc holder.
- c. Position disc washer and retain with screw.

3. Assembly

- a. Use reverse procedure for assembly with the following special instruction.
- b. To ease cap installation, apply a thin coating of O-ring lubricant or any FDA approved grease to the O-ring prior to assembly.
- c. Test unit to insure proper operation.

TESTING

All mechanical devices should be inspected on a regular basis to ensure they are working correctly. The assembly should be tested at time of initial installation, after servicing or maintenance, and at least annually thereafter. Acceptable test procedures are published by the Foundation for Cross Connection Control and Hydraulic Research at the University of Southern California (USC), The American Water Works Association (AWWA), The American Society of Sanitary Engineering (ASSE Series 5000) and the Canadian Standards Association (CAN/CSA B64•10). Please consult the regulatory authority in your area for more specific information.

HOW TO ORDER REPAIR KITS

1. Locate item number and kit number in this maintenance manual.
2. Verify the size of the valve the parts are to be used for.
3. Provide full model number located on I.D. plate.
4. Record kit number.
5. A serial number (located on the I.D. plate) will assist in ordering the proper kits.
6. Contact your local FEBCO Parts Distributor.

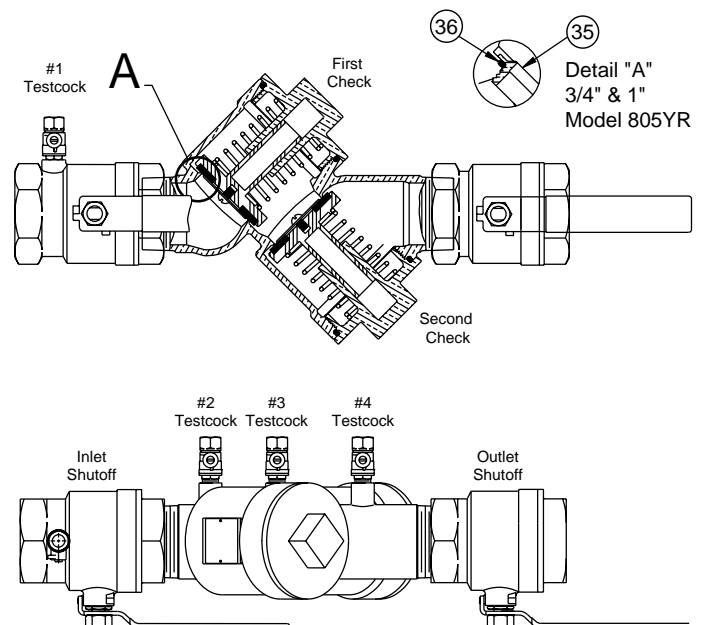
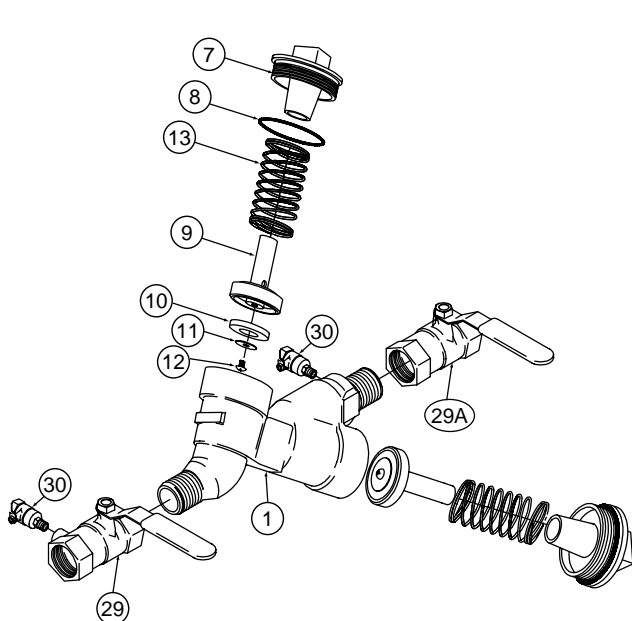

MODEL 805Y PARTS / REPAIR KITS

Model 805Y

Fig No.	Description	Qty.	3/4"	1"	1 1/2"	2"
1	Body	-	-	-	-	-
7	Cap	2	101-134	101-134	101-135	101-135
8	O-ring	2	398-226-72	398-226-72	398-235-72	398-235-72
9	Disc Holder	2	500-270	500-270	500-278	500-278
10	Seat Disc	2	400-099	400-099	400-103	400-103
11	Washer	2	300-084	300-084	300-108	300-108
12	Screw	2	516-543-03	516-543-03	516-543-03	516-543-03
13	Spring	2	630-115	630-115	630-118	630-118
29	Ball Valve - Inlet	2	781-053	781-054	781-056	781-057
29A	Ball Valve - Outlet	2	781-048	781-049	781-051	781-052
30	Testcock	4	781-074	781-074	781-075	781-075

Model 805Y and 805YB Assemblies / Kits

Rubber Parts (Items: 8, 10 (2)each)	905-042	905-042	905-053	905-053
Check Assembly (Items: 8, 9, 10, 11, 12)	905-044	905-044	905-055	905-055

Model 805YB

Model 805YB utilizes the same components as the 805Y with the exception of the following:

Fig No.	Description	Qty.	3/4"	1"	1 1/2"	2"
13	Spring	2	630-167			

Model 805YS

Model 805YS utilizes the same components as the 805Y with the exception of the following:

Fig No.	Description	Qty.	3/4"	1"	1 1/2"	2"
10	Seat Disc	2	400-099s	400-099s	400-103s	400-103s

805YS Assemblies / Kits

Rubber Parts (Items: 8, 10 (2)each)	905-042s	905-042s	905-053s	905-053s
Check Assembly (Items: 8, 9, 10, 11, 12)	905-044s	905-044s	905-055s	905-055s

Model 805YR

Model 805YR utilizes the same components as the 805Y with the exception of the following:

Fig No.	Description	Qty.	3/4"	1"	1 1/2"	2"
35	Seat Ring	2	110-023	110-023		
36	O-ring	2	398-028-72	398-028-72		

Model 805Y Commerical Parts

Item	Description	Material	3/4"	1"	1 1/2"	2"
8	O-Ring	Nitrile	568-226 2" x 2 1/4" x 1/8"	568-226 2" x 2 1/4" x 1/8"	568-235 3 1/8" x 3 3/8" x 1/8"	568-235 3 1/8" x 3 3/8" x 1/8"
29	Ball Valve	Bronze	3/4" NPT	1" NPT	1 1/2" NPT	2" NPT
30	Testcock	Brass	1/8" NPT	1/8" NPT	1/4" NPT	1/4" NPT

These parts are commercially available through most hardware distributors or retailers. Shut-offs valves, testcocks, flange gaskets, etc. are also commercially available but not listed.

FREEZE PROTECTION

The backflow prevention assembly may be subject to damage if the internal water is allowed to freeze. The unit must be protected from freezing using a heated enclosure, insulation heat tape, or other suitable means. The unit must always be accessible for testing and maintenance. If the system will be shut down during freezing weather, use the following procedures to drain internal passages.

Ball Valve Shut-Off Draining Procedure

If the assembly has been installed with ball valve shut-off valves, they must also be properly drained to prevent freeze damage. After draining procedure has been completed on the backflow prevention assembly, position all ball valve shut-offs and test cocks in a half open/half closed (45 degree) position.

Open the ball valve approximately 45 degrees while draining the pipeline and assembly to allow water between the ball valve and valve body to drain. Leave the ball valve in this position for the winter to prevent freeze damage.

The ball valve must be fully closed before the system is repressurized. **OPEN AND CLOSE BALL VALVES SLOWLY TO PREVENT DAMAGE TO THE SYSTEM CAUSED BY WATER HAMMER.**

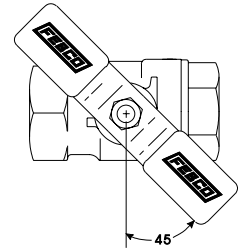

Main Valve Draining Procedure (3/4" - 2")

1. Close the main shut-off valve.
2. Open the inlet drain.
3. Open the inlet and outlet ball valves 45 degree (half open, half closed).
4. Open all testcocks.
5. Open the outlet drain.
6. Remove the cover and inlet check module until all water inside valve drains back out through inlet drain.
7. If you *blowout* the piping downstream of the backflow assembly using compressed air: Connect the air supply to the outlet drain and close the outlet ball valve. After clearing the system with air, partially open the outlet ball valve. Leave all drain valves, testcocks, and ball valves in half open/half closed position for the winter.

WARRANTY

All products manufactured and sold by CMB Industries, Inc. carry with them the following warranty: CMB Industries, Inc. warrants to the original purchaser (who is the end user) all products manufactured by it will be free from defects in workmanship and material for a period of one (1) year from the date of original shipment.

CMB Industries, Inc. also warrants that all internal components of 1/2" through 2" Model 850/860 and 1/2" through 1" Model 766 products, will be free from defects in workmanship and material for a period of five (5) years from the date of original shipment and also that the body only of the 1/2" through 1 1/4" Model 765 will be subject to a lifetime warranty against damage by freezing.

This warranty is applicable provided such products are used under normal conditions within the recognized pressure, flow and temperature limits and are given normal service and care. CMB INDUSTRIES, INC. MAKES NO OTHER REPRESENTATION OR WARRANTY OF ANY KIND, EXPRESSED OR IMPLIED, IN FACT OR IN LAW, AND EXPRESSLY DISCLAIMS ALL OTHER WARRANTIES, INCLUDING WITHOUT LIMITATION, THE WARRANTIES OF MERCHANTABILITY OR FITNESS FOR PARTICULAR PURPOSE. In the event of a defect in material or workmanship of a product covered by this warranty, CMB Industries, Inc. shall, at its sole option, repair or replace such defective product. CMB Industries, Inc. shall not be liable for any labor required to repair or replace any product covered by this warranty. This warranty is void with respect to any such product which is altered or tampered with by anyone without prior consent of CMB Industries, Inc. CMB Industries, Inc. shall not be liable under any circumstances for damages caused by accident, misuse or abuse of the product or for failure to follow the installation, maintenance or operating instructions. **IN NO EVENT SHALL CMB INDUSTRIES BE LIABLE FOR CONSEQUENTIAL, INCIDENTAL, INDIRECT, PERSONAL INJURY, PROPERTY OR PUNITIVE DAMAGES.**

To make a claim under this warranty, the buyer must notify the factory in writing within ten (10) days of discovery of any claimed defects or workmanship, and if authorized by the factory, shall return the product in the same condition as when received by the buyer, transportation prepaid, to the factory or to such other location as directed by the factory. If said returned product is found by the factory to be defective in workmanship or materials, it shall be repaired or replaced without charge, pursuant to the terms of this warranty. This warranty excludes component parts or appurtenances not manufactured by CMB Industries, Inc. Any claims with respect to such equipment must be made to the manufacturer thereof in accordance with the terms of the warranty, if any, given by such manufacturer, or pursuant to such warranties as may exist by law. The physical or chemical properties of CMB Industries, Inc. products represent typical, average values obtained in accordance with test methods and are subject to normal manufacturing variations. This information is supplied as a technical service and is subject to change without notice.